



Monitoring Report

CARBON OFFSET UNIT (CoU) PROJECT



Title: 19.5 MW WIND POWER PROJECT IN RAJASTHAN BY LEAP GREEN ENERGY PVT LTD

Version 1.0

UCR ID 448

Date 04/07/2024

First CoU Issuance Period: 8 years, 4 months

Monitoring Period: 01/09/2015 to 31/12/2023



Monitoring Report (MR)
CARBON OFFSET UNIT (CoU) PROJECT

Monitoring Report	
Title of the project activity	19.5 MW WIND POWER PROJECT IN RAJASTHAN BY LEAP GREEN ENERGY PVT LTD
UCR Project Registration Number	448
Version	1.0
Completion date of the MR	04/07/2024
Monitoring period number and duration of this monitoring period	Monitoring Period Number: 1st Duration of this monitoring Period: (first and last days included (01/09/2015 to 31/12/2023))
Project participants	LEAP GREEN ENERGY PRIVATE LIMITED
Host Party	India
Applied methodologies and standardized baselines	CDM UNFCCC Methodology ACM0002: Grid connected electricity generation from renewable sources- Version 21.0
Sectoral scopes	01 Energy industries (Renewable/Non-Renewable Sources)
Estimated amount of GHG emission reductions for this monitoring period in the registered PCN	2015: 4373 CoUs /yr (4373 tCO ₂ eq/yr)
	2016: 20709 CoUs/yr (20709 tCO ₂ eq/yr)
	2017: 20932 CoUs /yr (20932 tCO ₂ eq/yr)
	2018: 18901 CoUs/yr (18901 tCO ₂ eq/yr)
	2019: 19253 CoUs/yr (19253 tCO ₂ eq/yr)
	2020: 17671 CoUs /yr (17671 tCO ₂ eq/yr)
	2021: 20568 CoUs/yr (20568 tCO ₂ eq/yr)
	2022: 18461 CoUs/yr (18461 tCO ₂ eq/yr)
	2023: 19356 CoUs/yr (19356 tCO ₂ eq/yr)
Estimated amount of total GHG emission reductions during this MR	160224 CoUs 160224 tCO ₂ eq)

SECTION A. Description of project activity

A.1. Purpose and general description of project activity >>

The Project "19.5 MW Wind Power Project in Rajasthan by Leap Green Energy Pvt Ltd" is a wind-based power generation facility comprising 15 wind turbines across four villages located in the Jaisalmer district of the state of Rajasthan. It has been operational since September 29, 2010, which is the earliest commissioning date. The project is owned by Leap Green Energy Private Limited (hereinafter referred to as the Project Proponent or PP).

a) Purpose of the project activity and the measures taken for GHG emission reductions >>

The purpose of the project activity is to utilize renewable wind energy for generation of electricity. The project activity replaces anthropogenic emissions of greenhouse gases (GHG's) into the atmosphere, by displacing the equivalent amount of electricity generation through the operation of existing fuel fossil fuel- based power plants and future capacity expansions connected to the grid. In the absence of the project activity the equivalent amount of electricity would have been generated from the fossil fuel-based power plant. Whereas the electricity generation from operation of Wind Energy Convertors (WEC) is emission free. Commissioning dates of the Wind Turbine Generator installed are shown in the below table:

Sr. No.	Make	No. x Capacity	Commissioning Date
1	Suzlon	2 X 1.25 MW	04/12/2010
2	Suzlon	3 X 1.25 MW	30/10/2010
3	Suzlon	7 X 1.25 MW 3 X 1.5 MW	29/09/2010 30/09/2010

The project will generate approximately **17,8027** MWh of electricity for this Monitoring Period. The net generated electricity from the project activity is for selling it to RDPPC (Rajasthan Discoms Power Procurement Centre) by the project proponent. A Power Purchase Agreement

is signed between PP and RDPPC. The project activity has been helping in greenhouse gas (GHG) emission reduction by using renewable resources (wind energy) for generating power which otherwise would have been generated using grid mix power plants, which is dominated by fossil fuel based thermal power plants. The actual CO_{2e} emission reduction by the project activity for the monitoring period 01/09/2015 to 31/12/2023 is 160224tCO_{2eq}.

b) Brief description of the installed technology and equipment>>

The project activity consists of 1500 kW, 1250 kW capacity WTGs respectively manufactured and supplied by Suzlon. This project Generate 19.5 MW power which is consumed by customers delivered by the Grid.

Project Name- Project capacity & unit Capacity – 19.5 MW & 15 Nos WTG

Power which is consumed by customers delivered by the Grid.

Main component of the windmill is explained below:

Main Tower

This is a very tall structure with a door and inside ladder at the bottom. The door is used to enter the tower for operation and maintenance.

Blades

The windmills are provided with three blades. The blades are self-supporting in nature made up of Fibre Reinforced Polyester. The blades are mounted on the hub.

Nacelle

The Nacelle is the one which contains all the major parts of a windmill. The nacelle is made up of thick rugged steel and mounted on a heavy slewing ring. Under normal operating conditions, the nacelle would be facing the upstream wind direction.

Hub

The Hub is an intermediate assembly between the wing and the main shaft of the wind turbine. Inside the hub, a system to actuate the aerodynamic brake is fitted. The hub is covered with nose cone.

Main Shaft

The shaft connects the gear box and the hub. Solid high carbon steel bars or cylinders are used

as main shaft. The shaft is supported by two bearings.

c) Relevant dates for the project activity (e.g. construction, commissioning, continued operation periods, etc.)>>

Provide the duration of the crediting period corresponding to the monitoring period covered in this monitoring report.

UCR Project ID: **UCR-448**

Start Date of Crediting Period: 01/09/2015

Project Commissioned: 29/10/2010

d) Total GHG emission reductions achieved or net anthropogenic GHG removals by sinks achieved in this monitoring period>>

The total GHG emission reductions achieved in this monitoring period is as follows:

Summary of the Project Activity and ERs Generated for the Monitoring Period	
Start date of this Monitoring Period	01/09/2015
Carbon credits claimed up to	31/12/2023
Total ERs generated (tCO _{2eq})	160224 tCO _{2eq}
Project Emission (tCO _{2eq})	0
Leakage Emission (tCO _{2eq})	0

e) Baseline Scenario>>

This section provides details of emission displacement rates/coefficients/factors established by the applicable methodology selected for the project. As per para 19 of the approved consolidated methodology ACM0002, version 21, if the project activity is the installation of a new grid connected renewable power plant/unit, the baseline scenario is the following:

“The baseline scenario is that the electricity delivered to the grid by the project activity would have otherwise been generated by the operation of grid-connected power plants and by the addition of new generation sources into the grid”.

A.2. Location of project activity>>

Country: India

Village	Installed Capacity	District	State
Sirwa	5000kW	Jaisalmer	Rajasthan
Sangana	4500kW	Jaisalmer	Rajasthan
Moda	7500kW	Jaisalmer	Rajasthan
Chord	2500kW	Jaisalmer	Rajasthan

The project is located at Sangana, Sirwa, Moda, and Chord village in Jaisalmer district of Rajasthan state, India. In Sirwa windmills of capacity (2x1.25) MW are installed. In Sangana, Sirwa, Moda & Chord windmill of capacity (3 x 1.5) MW & (7 x 1.25) are installed. In Sangana, Sirwa, Moda & Chord windmills of capacity (3 X 1.25) MW are installed.

The representative Location of map is included below:

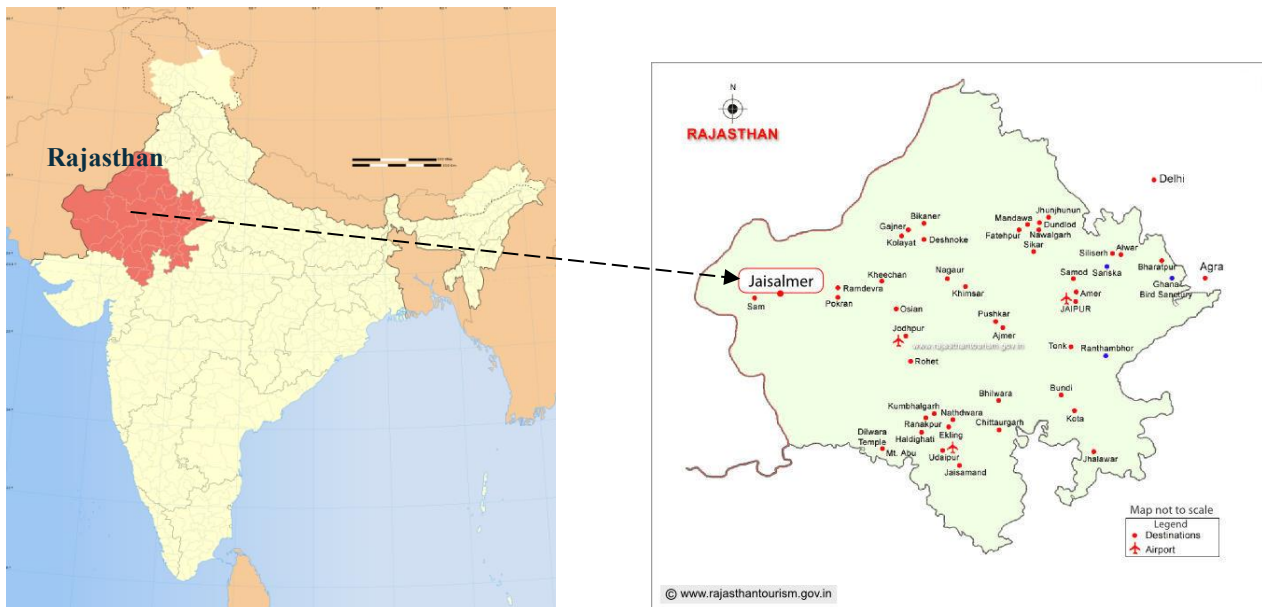

Project Activity

Loc No	Make	Site	Capacity	Village	Latitude	Longitude
AK249	Suzlon	Akal	1500	Sangana	26.80342	71.115722
AK279	Suzlon	Akal	1500	Sangana	26.80147	71.132583
AK408	Suzlon	Akal	1500	Sangana	26.78594	71.110167
AK223	Suzlon	Akal	1250	Chord	26.76533	71.137806

AK30	Suzlon	Akal	1250	Chord	26.70306	71.102083
AK31	Suzlon	Akal	1250	Moda	26.70006	71.104361
AK32	Suzlon	Akal	1250	Moda	26.69747	71.106583
AK33	Suzlon	Akal	1250	Moda	26.69317	71.109056
AK26	Suzlon	Akal	1250	Sirwa	26.68842	71.100056
AK35	Suzlon	Akal	1250	Moda	26.68886	71.115833
AK36	Suzlon	Akal	1250	Moda	26.68636	71.117194
AK25	Suzlon	Akal	1250	Sirwa	26.68	71.106806
AK37	Suzlon	Akal	1250	Moda	26.68203	71.117917
AK16	Suzlon	Akal	1250	Sirwa	26.66081	71.090639
AK15	Suzlon	Akal	1250	Sirwa	26.65869	71.094722

Loc No	Site Name	WEG	Wind turbine capacity	capacity in kW
		No		
AK 16		473139	1250 kw	2500
AK25	Sirwa site	64273398	1250 kw	
AK26	Sangana, Sirwa, Chicha, Modha & Chord	64260371	1250 kw	13250
AK15		64255991	1250 kw	
AK33		64263586	1250 kw	
AK35		64263586	1250 kw	
AK36		64261003	1250 kw	
AK37		64258610	1250 kw	
AK249		51510081	1500kw	
AK279		51510076	1500kw	
AK408		51510059	1500kw	
AK223		64256300	1250 kw	
AK30	Sangana, Sirwa, Moda & Chord	64274769	1250 kw	3750
Ak31		64270858	1250 kw	
AK32		64263584	1250 kw	
				19,500kw

A.3. Parties and project participants >>

Party (Host)	Participants
--------------	--------------

India	LEAP GREEN ENERGY PRIVATE LIMITED
-------	--------------------------------------

A.4. References to methodologies and standardized baselines >>

SECTORAL SCOPE - 01 Energy industries (Renewable/Non-renewable sources

TYPE I - Renewable Energy Projects

CATEGORY- ACM0002.: “Grid connected electricity generation from renewable sources- Version 21.0.”

A.5. Crediting period of project activity >>

Type- Renewable

State date- 01/09/2015

Length of the crediting period corresponding to this monitoring period: 8years 4months –
01/09/2015-31/12/2023

A.6. Contact information of responsible persons/entities >>

Contact Person- Lokesh Jain

Email- lokesh.jain@viviidgreen.com

Phone no- 91 89208 56146

Address- Sri Krishna Complex, New Link Road, Opp. Laxmi Industrial Estate, Andheri (West),
Mumbai - 400053

SECTION B. Implementation of project activity

B.1. Description of implemented registered project activity >>

a) Provide information on the implementation status of the project activity during this monitoring period in accordance with UCR PCN>>

The main Purpose of the project activity is the implementation and operation of 19.5MW wind farms to generate electricity in high wind speed areas of Rajasthan. Leap Green Energy Private Limited is the Project Proponent of these wind farm. The project was commissioned on several dates by the respective authority of government of Rajasthan. The applied technology is one of the most environment friendly technologies available as the operation of the wind power plant does not emit any GHGs or any other harmful gases unlike the operation of conventional power plant. The project activity has used the reliable and proven technology to ensure that an environmentally safe and sound technology has been implemented.

b) For the description of the installed technologies, technical process and equipment, include diagrams, where appropriate>>

All the machines are **S66 & S82** make and have been developed by Suzlon Energy Ltd. (SUZLON). The Suzlon flexi-slip system provides efficient control of the load and power control, and the turbine operation is effectively controlled by the Suzlon controller.

Leveraging the principles of kinetic energy conversion, wind energy generation harnesses the power of moving air masses. Wind turbines act as sophisticated windmills, their aerodynamically designed blades capturing the kinetic energy of wind. This captured energy is then converted into mechanical energy as the blades rotate. A connected generator utilizes this rotational motion to induce electrical current, resulting in the production of clean electricity without greenhouse gas emissions.

Some of the salient features of the project equipment can be found in the below mentioned table.

MODEL	S66-1250kW	S82-1500kW
OPERATING DATA		
Rated power	1250 kW	1,500 kW
Cut-in wind speed	4 m/s	4 m/s
Rated wind speed	12 m/s	12 m/s
Cut-off wind speed	20 m/s	20 m/s

Survival wind speed	52.5 m/s	52.5 m/s
ROTOR		
Type	3 Blades, Upwind/Horizontal axis	3 Blades, Upwind/Horizontal axis
Diameter	66 m	82 m
Rotational speed at rated power	20.62 rpm	15.6 to 16.3 rpm
Rotor blade material	Epoxy bonded fiber glass	Epoxy bonded fiberglass
Swept area	3,421 m ²	5,281 m ²
Power regulation	Active pitch regulated	Active pitch regulation
GEARBOX		
Nominal load	1,390 kW	1,650 kW
Type of cooling	Forced oil cooling lubrication system	Forced oil cooling lubrication system
Ratio	1:74.9	1:95.24 (Hansen) & 1:95:1601 (Winergy)
GENERATOR		
Type	Dual speed induction generator (asynchronous)	Induction generator with slip rings, variable rotor resistances via Suzlon Flexi
Speed at rated power	1,006/1,506 rpm	1,511 rpm
Rated voltage	690 V AC (phase to phase)	690 V AC (phase to phase)
Frequency	50 Hz	50 Hz
Insulation	Class H	Class H
Enclosure	IP 56	IP 54 / IP 23
Cooling system	Air cooled (IC 411)	Air cooled (IC 616)
TOWER		
Tower height	72 m	76.1 m
Hub height (including foundation)	74.5 m	76.8 m

The Project boundary includes the physical, geographical site(s):

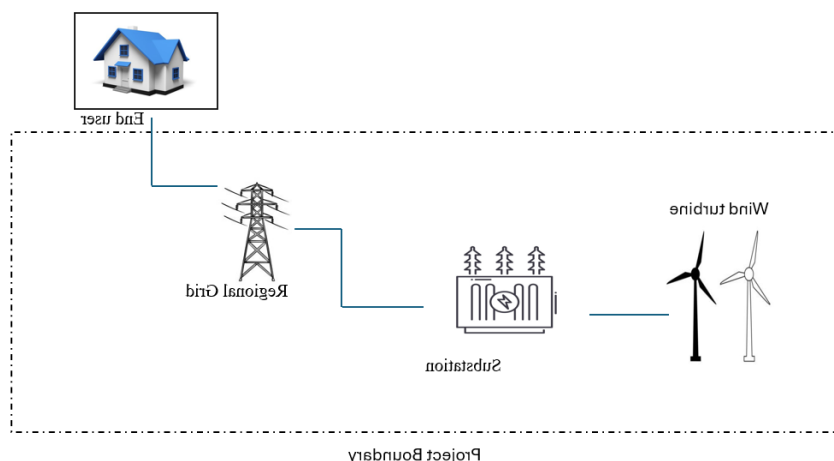

B.2 Do no harm or Impact test of the project activity>>

There are social, environmental, economic and technological benefits which contribute to sustainable development.

Social benefits:

- The project activity will lead to the development of supporting infrastructure such as road network etc., in the wind park location, the access to which is also provided to the local population.
- The project activity will lead to alleviation of poverty by establishing direct and indirect benefits through employment generation and improved economic activities by strengthening of local grid of the state electricity utility.
- Use of a renewable source of energy reduces the dependence on imported fossil fuels and associated price variation thereby leading to increased energy security.

Environmental benefits:

- The project activity employs renewable energy source for electricity generation instead of fossil fuel- based electricity generation which would have emitted gaseous, liquid and/or solid effluents/wastes.
- Being a renewable resource, using wind energy to generate electricity contributes to resource conservation. Thus, the project causes no negative impact on the surrounding environment and contributes to environmental well-being.

Economic benefits:



- The project activity requires temporary and permanent, skilled and semi-skilled manpower at the wind park; this will create additional employment opportunities in the region.
- The generated electricity will be fed into the NEWNE regional grid through local grid, thereby improving the grid frequency and availability of electricity to the local consumers (villagers & sub- urban habitants) which will provide new opportunities for industries and economic activities to be setup in the area thereby resulting in greater local employment, ultimately leading to overall development.

Technical benefits:

- Increased interest in wind energy projects will further push R&D efforts by technology providers to develop more efficient and better machinery in future.

United Nations Sustainable Development Goals:

The project activity generates electrical power using wind energy, which is generated from windmills, thereby displacing non-renewable fossil resources resulting to sustainable, economic and environmental development. In the absence of the project activity equivalent amount of power generation would have taken place through fossil fuel dominated power generating stations. Thus, the renewable energy generation from project activity will result in reduction of the greenhouse gas emissions.

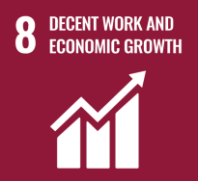
SDG Goals	Description
<p>Goal 2</p> 	<p>This project activity promotes good health by providing daily essentials to the local people in the vicinity of the project activity.</p>
<p>Goal 4</p> 	<p>This Project activity promotes educational amenities that can directly and indirectly help students achieve quality or better education. Also Support underprivileged or rural schools with required and unlocked various opportunities for school children.</p>
<p>Goal 6</p> 	<p>This project activity installed RO water system to provide clean water to the local community. This sustainable solution ensures every person has access to safe drinking water.</p>
<p>Goal 8</p> 	<p>This project activity generates additional employment in the operations and maintenance of the wind farm for the local people. This project will achieve full and productive employment and decent work.</p>

Goal 13		This 19.5 MW wind power project meets the SDG 13 goal by displacing fossil fuel with clean energy. This project is expected to reduce 160224 tCO ₂ emission.
---------	---	---

B.3. Baseline Emissions>>

The baseline scenario identified at the PCN stage of the project activity is:

In the absence of the project activity, the equivalent amount of electricity would have been generated from fossil fuel-based power plants and exported to the regional grid (which is connected to the unified Indian Grid system) as national grid is predominantly sourcing from fossil fuel-based power plants. Hence, baseline scenario of the project activity is the grid-based electricity system, which is also the pre-project scenario.

Schematic diagram showing the baseline scenario:

Baseline Scenario:

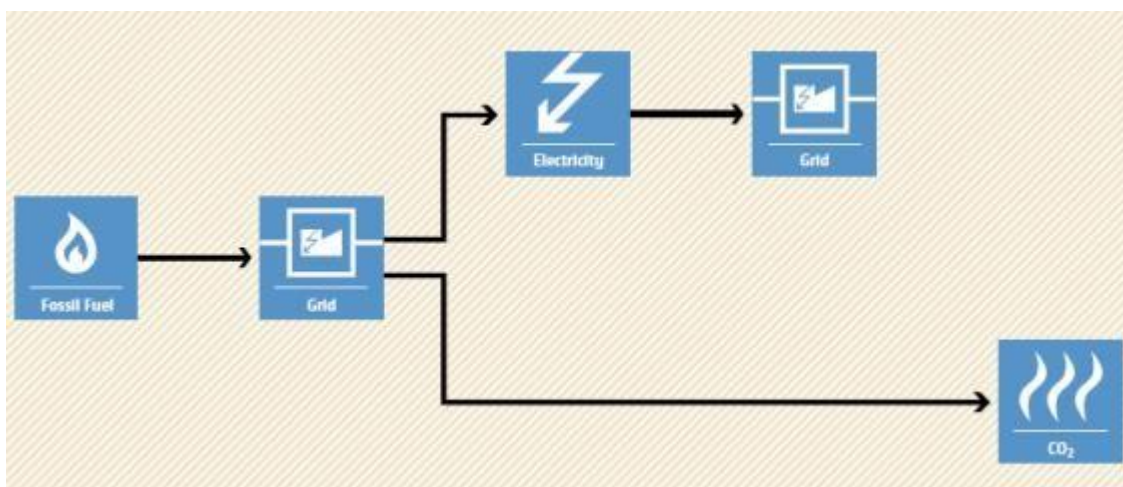

Project Scenario:

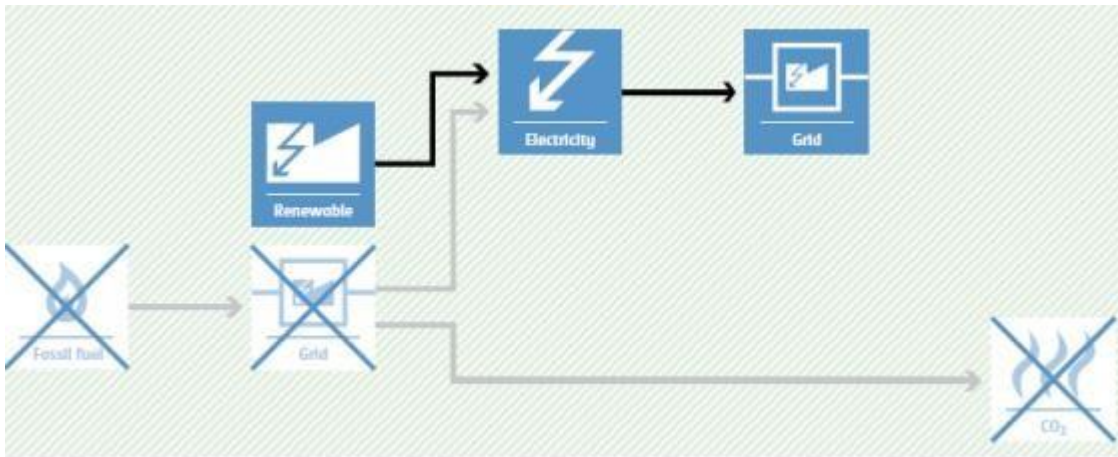

B.4. Debundling>>

This project is not a debundled component of a larger registered carbon offset project activity.

SECTION C. Application of methodologies and standardized baselines

C.1. References to methodologies and standardized baselines >>

SECTORAL SCOPE – 01 Energy industries (Renewable/Non-renewable sources)

TYPE I- Renewable Energy Projects

CATEGORY- ACM0002.: “Grid connected electricity generation from renewable sources
Version21.0.”

C.2. Applicability of methodologies and standardized baselines >>

The project activity involves generation of grid connected electricity from the construction and operation of a new wind power-based power project for selling it to grid. The project activity has an installed capacity of 19.5 MW which will qualify for a large-scale project activity. The project status corresponds to the methodology ACM0002, Version21.0 and applicability of methodology is discussed below.

Applicability Criteria.	Project Case
<p>1) This methodology is applicable to grid-connected renewable energy power generation project activities that:</p> <ul style="list-style-type: none"> (a) Install a Greenfield power plant; (b) Involve a capacity addition to (an) existing plant(s); (c) Involve a retrofit of (an) existing operating plant(s)/unit(s); (d) Involve a rehabilitation of (an) existing plant(s)/unit(s); or (e) Involve a replacement of (an) existing plant(s)/unit(s). 	<p>The proposed project activity is a green field Plant, that is to connected Grid. Therefore, the project activity satisfies the point (a).</p>
<p>2) In case the project activity involves the integration of a BESS, the methodology is applicable to grid-connected renewable energy power generation project activities that:</p> <ul style="list-style-type: none"> (a) Integrate BESS with a Greenfield power plant; (b) Integrate a BESS together with implementing a capacity addition to (an) existing solar photovoltaic or wind power plant(s)/unit(s); (c) Integrate a BESS to (an) existing solar photovoltaic or wind power plant(s)/unit(s) without implementing any other changes to the existing plant(s); (d) Integrate a BESS together with implementing a retrofit of (an) existing solar photovoltaic or wind power plant(s)/unit(s). 	<p>The project activity is the installation of 19.5 MW Wind power project and does not involve the integration of a Battery Energy Storage System (BESS). This condition is not applicable for this project.</p>
<p>3) The methodology is applicable under the following conditions:</p> <ul style="list-style-type: none"> (a) Hydro power plant/unit with or without reservoir, wind power plant/unit, geothermal power plant/unit, solar power plant/unit, wave power plant/unit or tidal power plant/unit; (b) In the case of capacity additions, retrofits, rehabilitations or replacements (except for wind, solar, wave or tidal power capacity addition projects) the existing plant/unit started commercial operation prior to the start of a minimum historical reference period of five years, used for the calculation of baseline emissions and defined in the baseline emission section, and no capacity expansion, retrofit, or rehabilitation of the plant/unit has been undertaken between the start of this minimum historical reference period and the implementation of the project activity; (c) In case of Greenfield project activities applicable under paragraph 5 (a) above, the project participants shall demonstrate that the BESS was an integral part of the design of the renewable energy project activity (e.g. by referring to feasibility studies or investment decision documents); (d) The BESS should be charged with electricity generated from the associated renewable energy power plant(s). Only during 	<p>The proposed project activity is the installation of a new Wind power plants without BESS integration. Therefore, the said criterion is not applicable</p>

exigencies 2 may the BESS be charged with electricity from the grid or a fossil fuel electricity generator. In such cases, the corresponding GHG emissions shall be accounted for as project emissions following the requirements under section 5.4.4 below. The charging using the grid or using fossil fuel electricity generator should not amount to more than 2 per cent of the electricity generated by the project renewable energy plant during a monitoring period. During the time periods (e.g. week(s), months(s)) when the BESS consumes more than 2 per cent of the electricity for charging, the project participant shall not be entitled to issuance of the certified emission reductions for the concerned periods of the monitoring period.

4) In case of hydro power plants, one of the following conditions shall apply:

- a) The project activity is implemented in an existing single or multiple reservoirs, with no change in the volume of any of reservoirs; or
- b) The project activity is implemented in an existing single or multiple reservoirs, where the volume of the reservoir(s) is increased and the power density calculated using equation (7) is greater than 4 W/m²; or
- c) The project activity results in new single or multiple reservoirs and the power density calculate equation (7), is greater than 4 W/m².
- d) The project activity is an integrated hydro power project involving multiple reservoirs, where the power density of any of the reservoirs, calculated using equation (7), is lower than or equal to 4 W/m², all of the following conditions shall apply.
 - i) The power density calculated using the total installed capacity of the integrated project, as per equation (8) is greater than 4W/m²;
 - ii) Water flow between reservoirs is not used by any other hydropower unit which is not a part of the project activity; Installed capacity of the power plant(s) with power density lower than or equal to 4 W/m² shall be: Lower than or equal to 15 MW; and Less than 10% of the total
 - iii) installed capacity of integrated hydro power project

The proposed project activity is the installation of Wind power plants/units. Therefore, the said condition is not applicable.

5) In the case of integrated hydro power projects, project proponent shall:

- a) Demonstrate that water flow from upstream power plants/units spill directly to the downstream reservoir and that collectively constitute to the generation capacity of the integrated hydro power project; or
- b) Provide an analysis of the water balance covering the water

The proposed project activity is the installation of a wind power plants/units. Therefore, the said criteria is not applicable

<p>fed to power units, with all possible combinations of reservoirs and without the construction of reservoirs. The purpose of water balance is to demonstrate the requirement of specific combination of reservoirs constructed under CDM project activity for the optimization of power output. This demonstration has to be carried out in the specific scenario of water availability indifferent seasons to optimize the water flow at the inlet of power units. Therefore, this water balance will take into account seasonal flows from river, tributaries (if any), and rainfall for minimum five years prior to implementation of CDM project activity.</p>	
<p>6)The methodology is not applicable to: a) Project activities that involve switching from fossil fuels to renewable energy sources at the site of the project activity, since in this case the baseline may be the continued use of fossil fuels at the site. b) Biomass fired power plants;</p>	<p>The proposed project activity is Greenfield wind power project and does not fall under any of the options (a) (b) (c). Therefore, the said criteria is not applicable.</p>
<p>7)In the case of retrofits, rehabilitations, replacements, or capacity additions, this methodology is only applicable if the most plausible baseline scenario, as a result of the identification of baseline scenario, is “the continuation of the current situation, that is to use the power generation equipment that was already in use prior to the implementation of the project activity and undertaking business as usual maintenance</p>	<p>The proposed project activity is the installation of wind power plants. Therefore, the said criteria is not applicable.</p>

C. 3 Applicability of double counting emission reductions >>

There is no double accounting of emission reductions in the project activity due to the following reasons:

- Project is uniquely identifiable based on its location coordinates,
- Project has dedicated commissioning certificate and connection point,
- Project is associated with energy meters which are dedicated to the consumption point for project developer.

C.4. Project boundary, sources and greenhouse gases (GHGs)>>

As per applicable methodology, the spatial extent of the project boundary includes the project power plant and all power plants connected physically to the electricity system that the project power plant is connected to. Hence, the project boundary includes the project site

where the power plant has been installed, associated power evacuation infrastructure, energy metering points, switch yards and other civil constructs and connected to the regional grid of Rajasthan.

	Source	GHG	Included?	Justification/Explanation
Baseline	Emissions from burning non-renewable wood	CO2	Included	Major source of emission
		CH4	Included	Major source of emission
	Emissions from animal manure stored on site	N2O	Excluded	Excluded for simplification. This is conservative
Project	Emissions from on-site electricity use	CO2	Excluded	Electricity is generated from collected biogas, hence these emissions are not accounted for. CO2 emissions from the decomposition of organic waste are not accounted
	Emissions from residue from anaerobic digester composting	CH4	Excluded	Excluded for simplification. This is conservative
		N2O	Excluded	Excluded for simplification. This is conservative

C.5. Establishment and description of baseline scenario (UCR Protocol) >>

As per the approved consolidated methodology ACM0002. Version-21, if the project activity is the installation of a new grid-connected renewable power plant, the baseline scenario is the following: “The baseline scenario is that the electricity delivered to the grid by the project activity would have otherwise been generated by the operation of grid-connected power plants and by the addition of new generation sources into the grid”.

The project activity involves setting up a new wind power plant to harness the green power from wind energy and sell it to the grid by signing a PPA. In the absence of the project activity, the equivalent amount of power would have been supplied by the Indian grid, which is fed mainly by fossil fuel fired plants. The power produced at grid from the other conventional sources which are predominantly fossil fuel based. Hence, the baseline for the project activity is the equivalent amount of power produced at the Indian grid.

A "grid emission factor" refers to a CO₂ emission factor (tCO₂/MWh) which will be associated with each unit of electricity provided by an electricity system. The UCR recommends an emission factor of 0.9 tCO₂/MWh for the 2013-2023 years as a conservative estimate for Indian projects not previously verified under any GHG program. Also, for the vintage 2021, the combined margin emission factor calculated from CEA database in India results into higher emission than the default value. Hence, the same emission factor has been considered to calculate the emission reduction under conservative approach.

¹

❖ Emission reductions are calculated as follows:

$$ER_y = BE_y - PE_y - LE_y \quad \text{(Eq. 1)}$$

Where,

ER_y = Emissions reductions in year y (t CO₂)

BE_y = Baseline emissions in year y (t CO₂)

PE_y = Project emissions in year y (t CO₂)

LE_y = Leakage emissions in year y (t CO₂)

Baseline Emissions

Baseline emissions include only CO₂ emissions from electricity generation in power plants that are displaced due to the project activity. The methodology assumes that all project electricity generation above baseline levels would have been generated by existing grid-connected power plants and the addition of new grid-connected power plants.

❖ The Baseline emissions in year y can be calculated as follows:

$$BE_y = EG_{PJ,y} \times EF_{Grid,y} \quad \text{(Eq. 2)}$$

¹ https://a23e347601d72166dcd6-16da518ed3035d35cf0439f1cdf449c9.ssl.cf2.rackcdn.com//Documents/UCRCoUStandardAug2022updatedVer6_090822220127104470.pdf

Where,

BE_y = Baseline emissions in year y (t CO₂)

$EGPJ_y$ = Quantity of net electricity generation that is produced and fed into the grid as a result of the implementation of the CDM project activity in year y (MWh)

$EF_{Grid,y}$ = Grid emission factor in year y (t CO₂/MWh)

Project Emissions

As per the applied methodology ACM0002, version 21 Paragraph 35, only emission associated with fossil fuel combustion. Since the project activity is a wind power project, project emission for renewable energy plant is nil.

Thus,

$$PE_y = 0 \quad \text{(Eq. 3)}$$

Leakage Emissions

In the project activity, there is no transfer of energy generating equipment and therefore the leakage from the project activity is considered as zero which is accordingly to Paragraph 39, Version 2.1.

Thus,

$$LE_y = 0 \quad \text{(Eq. 4)}$$

Year	Net Quantity of net electricity generation supplied by the project activity to the grid in year y	Emission Factor	Baseline Emissions	Project emissions or actual net GHG removals by sink	Leakage	Emission reductions or net anthropogenic GHG removals by sinks
	[MWh]	(tCO ₂ e/MWh)	(tCO ₂ e)	(tCO ₂ e)	(tCO ₂ e)	(tCO ₂ e)
		[EF _y]	[BE _y] = [EG _{facility, y}] * [EF _y]	[PE _y]	[LE _y]	[ER _y] = [BE _y] - [PE _y] - [LE _y]
Year 1	4859	0.9	4373	0	0	4373
Year 2	23010	0.9	20709	0	0	20709
Year 3	23258	0.9	20932	0	0	20932
Year 4	21001	0.9	18901	0	0	18901

Year 5	21393	0.9	19253	0	0	19253
Year 6	19635	0.9	17671	0	0	17671
Year 7	22853	0.9	20568	0	0	20568
Year 8	20512	0.9	18461	0	0	18461
Year 9	21506	0.9	19356	0	0	19356
Total	178027		160224			160224

C.6. Prior History>>

The project activity is a large-scale wind power project, and this project was never applied under any other GHG mechanism prior to this registration with UCR. Also, the capacity or the total project has not been applied for any other environmental crediting or certification mechanism. Hence the project will not cause double accounting of carbon credits (i.e., COUs).

C.7. Monitoring period number and duration>>

First Issuance Period : 8 years 4 Months
 Crediting Period : 01/09/2015 to 31/12/2025
 Monitoring Period : 01/09/2015 to 31/12/2023

C.8. Changes to start date of crediting period >>

The start date of the crediting period is considered from 01/09/2015 (The date from the legal ownership of the Project Participant).

C.9. Permanent changes from PCN monitoring plan, applied methodology or applied standardized baseline >>

There are no permanent changes from the registered PCN monitoring plan and applied methodology.

C.10. Monitoring plan>>

Data and Parameters available at validation (ex-ante values):

Data / Parameter	<i>EF</i> Grid,y
Data unit	tCO ₂ /MWh

Description	A "grid emission factor" refers to a CO2 emission factor (tCO2/MWh) which will be associated with each unit of electricity provided by an electricity system. The UCR recommends an emission factor of 0.9 tCO2/MWh for the 2013 - 2020 years as a fairly conservative estimate for Indian projects not previously verified under any GHG program. Hence, the same emission factor has been considered to calculate the emission reduction under conservative approach.
Source of data	https://a23e347601d72166dcd6-16da518ed3035d35cf0439f1cdf449c9.ssl.cf2.rackcdn.com//Documents/UCRCoUStandardAug2022updatedVer6_090822220127104470.pdf
Value applied	0.9
Measurement methods and procedures	-
Monitoring frequency	Ex-ante fixed parameter
Purpose of Data	For the calculation of Emission Factor of the grid

Data and Parameters to be monitored.

Data / Parameter	EG_{pj,y}
Data unit	MWh
Description	Net electricity supplied to the NEWNE grid facility by the project activity.
Source of data	Joint Meter Reading Report
Measurement procedures (if any):	<p>Data Type: Measured</p> <p>Monitoring equipment: Energy Meters are used for monitoring</p> <p>Archiving Policy: Electronic</p> <p>Calibration frequency: Once in 5 years (considered as per provision of CEA India).</p> <p>Calibration frequency: once in five years (as per CEA Indian provision)</p> <p>Cross checking: Quantity of net electricity supplied to or consumed at PP's facility will be cross checked from the monthly bills or invoices raised by Discom whichever is applicable. The Net electricity supplied to the grid will be calculated by the values of Electricity export to the grid.</p> <p>The Net electricity is recorded as following: Thus, EG_{pj,y}= EG_{net}, Export.</p>

Measurement Frequency:	Frequency -Monthly The net energy exported to the grid is measured every month using calibrated energy meter by the State Electricity Board authorities in the presence of the project implementer or its representatives. The meter/s shall be jointly inspected and sealed by authorised representatives of the company and the state utility. Measuring procedure: Will be measured by an export-import energy meter. The net electricity exported by the project plant would either be directly sourced as a measured parameter or be calculated by deducting the amount of imported electricity from the total amount of exported electricity.
QA/QC procedures applied:	Continuous monitoring, hourly measurement monthly recording. Tri-vector (TVM)/ABT energy meters with accuracy class 0.2s.
Purpose of data:	The Data/Parameter is required to calculate the baseline emission.
Value applied:	160224 tCO ₂ eq
QA/QC procedures applied:	Calibration of the Main meters will be carried out once in five (5) years as per National Standards (as per the provision of CEA, India) and faulty meters will be duly replaced immediately as per the provision of power purchase agreement.
Purpose of data:	Calculation of baseline emission.

Appendix-1 Calibration Details >>

Company Name	Plant Capacity(MW)	Location	Commissioning Date	Calibration date	Calibration validity	Calibration delay
Leap Green Energy Pvt. Ltd	19.5	Rajasthan	29-09-2010	20-04-2018	20-04-2023	01.01.2016 to 31.10.2017 01.01.2023 to 31.01.2024



DARSH CALIBRATIONS PVT. LTD.

B-154, 1st Extn. Kamla Nehru Nagar,
Jodhpur-342008(Raj.) India



NABL :- CC-2070

CALIBRATION CERTIFICATE

Certificate No. : DCPL/CAL/18-19/047 Page 1 of 4

1	Name and address of customer	M/s Suzlon Energy Ltd. Metering No. 81 Akal District: Jaisalmer, Rajasthan.
Reference		
	Customer Reference Number	PO No.4500589398 Dated:-05-02-2018
	Date of receipt of UUC	20/04/2018
	Condition of UUC	Satisfactory
3	Location of calibration	Suzlon 220Kv GSS Akal
4	Calibration Certificate Details	
	Date of Issue	07/05/2018
	Date of Calibration	20/04/2018
	Due Date of calibration(As requested by the customer)	19/04/2019
5	Description of equipment under calibration	
	Name	3 PHASE ENERGY METER
	Sr.No.	RJB90208(Main Meter)(GSS END)
	Make	SECURE
	Type	3phase 4wire
	Model	Premier 300
	Voltage	3x63.5V
	Current Ratio	Ib=1A,Imax=2A
	Class	0.2s
	Meter constant	160000Pulses/Unit/MWh/MVArh
	Frequency	50Hz
6	Environmental Conditions of Measurements :	
	Temperature	27.5°C-27.5°C
	Humidity	50-55%
7	Witnessed by:-	
	Mr. S.P.Mathur	AEN,M&P,Jaisalmer.
	Mr.Vishal Singh	Site Incharge, M/s Suzlon Energy Ltd.Jaisalmer,Rajasthan.

NOTE:-

- 1.This calibration certificate refers only to the particular item submitted for calibration.
 - 2.This certificate shall not be reproduced except in full unless written permission for the publication of an approved abstract has been obtained from Darsh Calibrations Pvt.Ltd. Jodhpur.
- The calibration results reported in this certificate are valid at the time of an under stated condition of measurement.

CALIBRATED/CHECKED BY

AUTHORIZED SIGNATORY

There is calibration delay for the monitoring period mentioned above. The error factor has been applied in net export values for delay period as meters were not calibrated as per the calibration frequency. As per VVS requirement: error factor of " $\pm 0.2\%$ " should be applicable for both export & import i.e. the measured values. However, net electricity generation is considered as per the registered monitoring plan, the separate export and import values are not available. Hence being conservative and to account for the error for both export & import, a cumulative error of " -0.4% " on net electricity generation has been applied for delay period.

https://cea.nic.in/wp-content/uploads/2020/02/meter_reg.pdf

Appendix II> Meter Change Details

SUZLON ENERGY LTD. - PHASE-81
220 KV SUB STATION,AKAL
277.10 MW WIND POWER UNIT, Akal, JAISALMER
JOINT METER READING

MONTHLY GENERATION RECORD FOR THE MONTH OF April-2017 READING TAKEN ON 01/05/2017

(A) MAIN METER OLD (220KV line 1st SEL-81) (B) MAIN METER NEW (220KV line 1st SEL-81)

MSB10311						RJB90208								
Sr. No	Parameters	Initial reading taken on 01/04/17	Final reading taken on 18/04/17	Diff.	M.F.	Total (A)	Sr. No	Parameters	Initial reading taken on 18/04/17	Final reading taken on 01/05/17	Diff.	M.F.	Total (B)	Net KWH (A+B)
1	H1 KWH Export	1857.76	1675.291314	17.53	800000	14025051	1	H1 KWH Export	0.5796	7.44	6.86	1600000	10976640	25001691
2	H1 KWH Import	12.23	12.329320	0.10	800000	79456	2	H1 KWH Import	0.1415	0.15	0.01	1600000	13600	93056
3	Net Export(KWH)					13945595	3	Net Export(KWH)					10963040	24908635
4	KVARH Exp. (Ind.)	160.66	160.910091	0.25	800000	200073	4	KVARH 1(Ind Exp.)	0.3679	0.42	0.05	1600000	83360	283433
5	KVARH Imp. (Ind.)	0.13	0.140188	0.01	800000	8150	5	KVARH 2(Cap.Imp.)	0.0473	0.05	0.00	1600000	4320	14550
6	KVARH Exp. (Cap.)	90.78	92.369106	1.59	800000	1271285	6	KVARH 3(Ind.Imp.)	0.1460	0.15	0.00	1600000	6400	2346965
7	KVARH Imp. (Cap.)	36.02	36.060610	0.04	800000	32488	7	KVARH 4(Cap.Exp.)	0.0377	0.71	0.67	1600000	1075680	36808
8	Net KVArh					1430719	8	Net KVArh					1148320	2579039
9	H1 KVAH (Exp.)	1904.80	1922.481473	17.68	800000	14145178	9	H1 KVAH (Exp.)	0.8402	7.75	6.91	1600000	11055680	25200858
10	H1 KVAH (Imp.)	39.77	39.881418	0.11	800000	89134	10	H1 KVAH (Imp.)	0.2856	0.29	0.00	1600000	7040	96174
11	CMD kVA (Exp.)	13.458	13.458	0.000	800000	0	11	CMD kVA (Exp.)	0.695	0.760	0.065	1600000	104000	104000
12	CMD kVA (Imp.)	0.697	0.697	0.000	800000	0	12	CMD kVA (Imp.)	0.153	0.153	0.000	1600000	0	0
13	Power Factor(Exp)			0.992			13	Power Factor(Exp)			0.993			
14	Power Factor(Imp)			0.891			14	Power Factor(Imp)			1.932			
15	Meter seal						15	Meter seal						
i	Meter body						i	Meter body						
ii	Meter terminal						ii	Meter terminal						
iii	Test terminal block						iii	Test terminal block						
iv	CTPT terminal cover box & body seal						iv	CTPT terminal cover box & body seal						
v	Meter panel box	OK	OK				v	Meter panel box	OK	OK				
16	MONTH OF IMPORT	Total days Current month	Total days Upto the month	initial Reading	Final Reading	Difference	Net Import	Total days Current month	Total days Upto the month	Difference	Net Import			
(i)	APRIL '17	1	1	0.14	0.15	0.0085	13600							

SUZLON ENERGY LTD. - PHASE-81
220 KV SUB STATION,AKAL
277.10 MW WIND POWER UNIT, Akal, JAISALMER
JOINT METER READING

MONTHLY GENERATION RECORD FOR THE MONTH OF April-2017 READING TAKEN ON 01/05/2017

(A) BACKUP METER OLD (220KV line 1st SEL-81) (B) BACKUP METER NEW (220KV line 1st SEL-81)

MSB10312						RJB90209								
Sr. No	Parameters	Initial reading taken on 01/04/17	Final reading taken on 18/04/17	Diff.	M.F.	Total (A)	Sr. No	Parameters	Initial reading taken on 18/04/17	Final reading taken on 01/05/17	Diff.	M.F.	Total (B)	Net KWH (A+B)
1	H1 KWH Export	1902.69	1920.22	17.53	800000	14023027	1	H1 KWH Export	0.9015	7.77	6.87	1600000	10989600	25012627
2	H1 KWH Import	12.47	12.58	0.11	800000	85220	2	H1 KWH Import	0.1479	0.15	0.002	1600000	3360	88580
3	Net Export(KWH)					13937807	3	Net Export(KWH)					10986240	24924047
4	KVARH Exp. (Ind.)	163.41	163.66012	0.25	800000	200096	4	KVARH 1(Ind Exp.)	0.3790	0.43	0.05	1600000	81600	281696
5	KVARH Imp. (Ind.)	0.13	0.14	0.01	800000	10598	5	KVARH 2(Cap.Imp.)	0.0405	0.04	0.00	1600000	-800	16358
6	KVARH Exp. (Cap.)	93.26	94.85	1.59	800000	1272776	6	KVARH 3(Ind.Imp.)	0.1464	0.15	0.00	1600000	5760	2338216
7	KVARH Imp. (Cap.)	36.88	36.93	0.05	800000	37065	7	KVARH 4(Cap.Exp.)	0.0441	0.71	0.67	1600000	1065440	36265
8	Net KVArh					1425209	8	Net KVArh					1142080	2567289
9	H1 KVAH (Exp.)	1950.41	1968.08	17.67	800000	14136624	9	H1 KVAH (Exp.)	1.1697	8.09	6.92	1600000	11072480	25209104
10	H1 KVAH (Imp.)	40.68	40.80	0.12	800000	95330	10	H1 KVAH (Imp.)	0.2846	0.29	0.01	1600000	8640	103970
11	CMD kVA (Exp.)	13.786	13.786	0.000	800000	0	11	CMD kVA (Exp.)	0.694	0.760	0.066	1600000	105600	105600
12	CMD kVA (Imp.)	0.600	0.600	0.000	800000	0	12	CMD kVA (Imp.)	0.177	0.180	0.00	1600000	4800	4800
13	Power Factor(Exp)			0.992			13	Power Factor(Exp)			0.993			
14	Power Factor(Imp)			0.894			14	Power Factor(Imp)			0.389			
15	Meter seal						15	Meter seal						
i	Meter body						i	Meter body						
ii	Meter terminal						ii	Meter terminal						
iii	Test terminal block						iii	Test terminal block						
iv	CTPT terminal cover box & body seal						iv	CTPT terminal cover box & body seal						
v	Meter panel box	OK	OK				v	Meter panel box	OK	OK				